

# SERIES 6682, 6683 .093" (∅2.36m/m) Wire-to-wire Connectors



**JH**



**STANDARDS**



E141311 (豪訊)

All bear JH mark

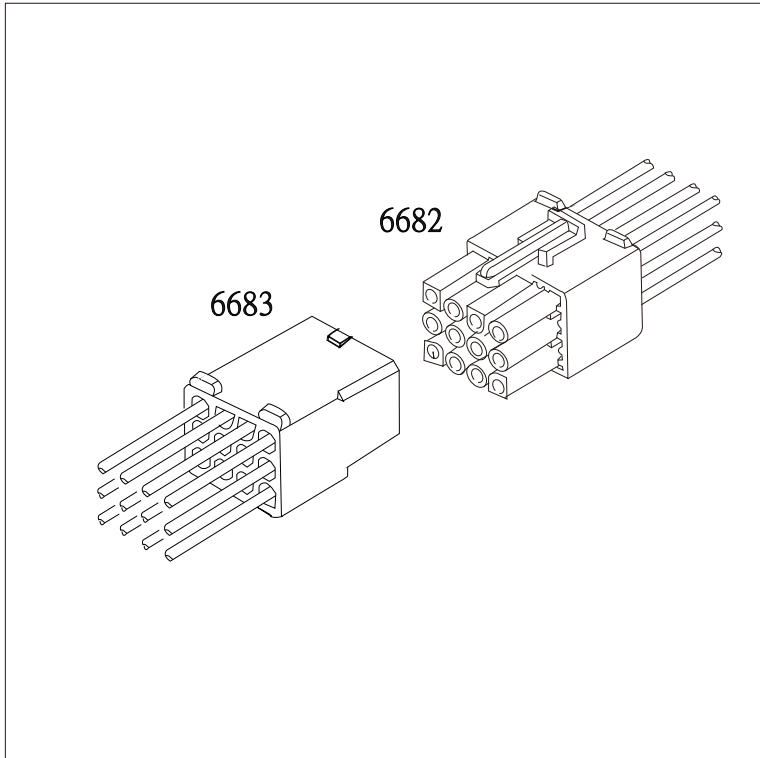

## SPECIFICATIONS

- ★ Circuit: 1, 2, 3, 4, 6, 9, 12, 15
- ★ Voltage rating: 600V AC, DC
- ★ Current rating: 12A, AC, DC
- ★ Withstanding voltage: 1500V AC/minute
- ★ Insulation resistance: 1000MΩ min
- ★ Temperature range: -25°C ~ +85°C
- ★ Unit(單位): m/m
- ★ Material(材質): UL94V-2 nylon 66
- ★ Tolerance(公差): ±0.3 m/m
- ★ 6680, 6681, 6682, 6683 退端器共用

| Part NO  | WIRE RANGE | O.D.OF WIRE INSULATION | MATERIAL | PLATING    | QUANTITY PER REEL |
|----------|------------|------------------------|----------|------------|-------------------|
|          | AWG        |                        |          |            |                   |
| T6680-A  | 20 - 14    | 1.9-3.5                | PHOSPHOR | TIN-Plated | 4000              |
| T6680-B  | 24 - 20    | 1.5-2.7                | PHOSPHOR | TIN-Plated | 5000              |
| T6680(中) | 22 - 14    | 1.7-3.5                | PHOSPHOR | TIN-Plated | 4000              |

| Part NO  | WIRE RANGE | O.D.OF WIRE INSULATION | MATERIAL | PLATING    | QUANTITY PER REEL |
|----------|------------|------------------------|----------|------------|-------------------|
|          | AWG        |                        |          |            |                   |
| T6681-A  | 20 - 14    | 1.9-3.5                | PHOSPHOR | TIN-Plated | 4000              |
| T6681-B  | 24 - 20    | 1.5-2.7                | PHOSPHOR | TIN-Plated | 5000              |
| T6681(中) | 22 - 14    | 1.7-3.5                | PHOSPHOR | TIN-Plated | 4000              |

**T** ERMINAL 6680 (A-高脚 High Heel)  
(B-低脚 Low Heel)  
中料帶 Conveyor

**T** ERMINAL 6681 (A-高脚 High Heel)  
(B-低脚 Low Heel)  
中料帶 Conveyor

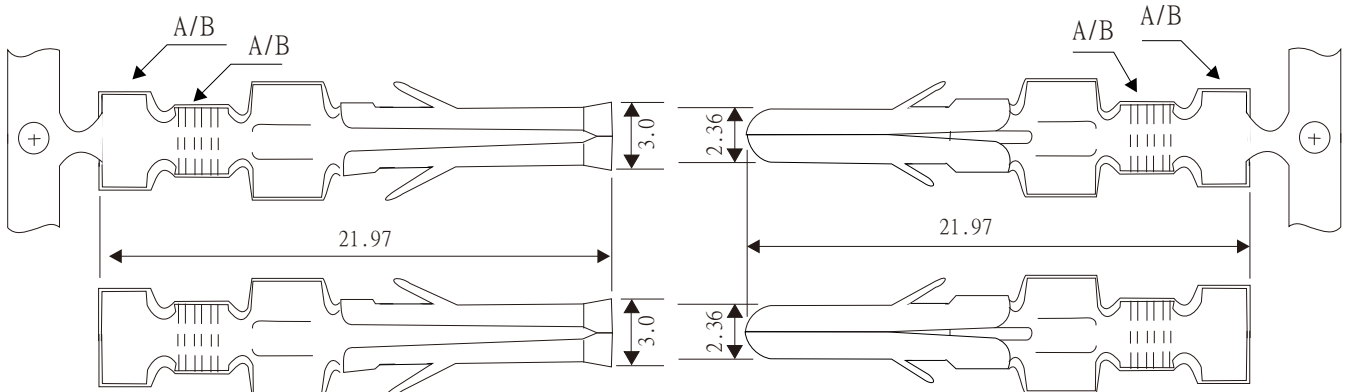

# H HOUSING 6682-01

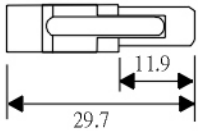
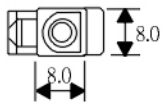

# H HOUSING 6683-01

Pcs/bag  
個數/袋  
500

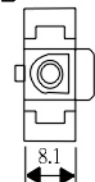
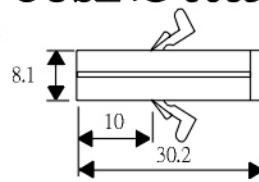

(6683E)

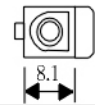
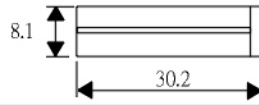

(6683)

# H HOUSING 6682-02

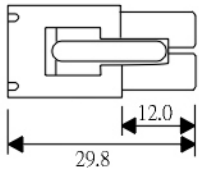
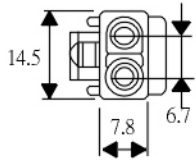

# H HOUSING 6683-02 6683E-02

Pcs/bag  
個數/袋  
500

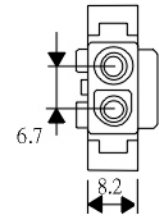
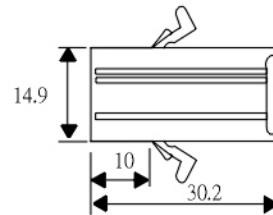

(6683E)

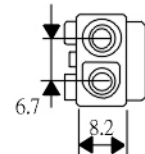
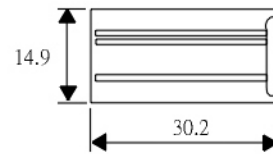

(6683)

# H HOUSING 6682-03

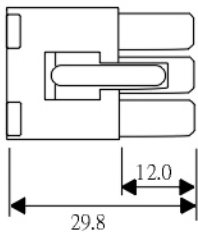
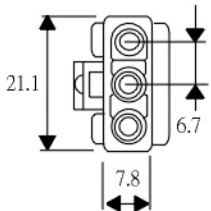

# H HOUSING 6683-03 6683E-03

Pcs/bag  
個數/袋  
500

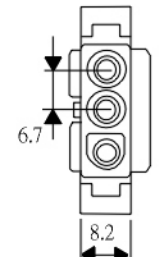
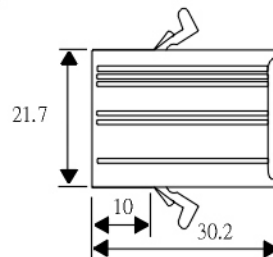

(6683E)

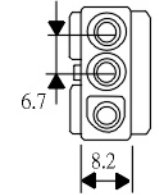
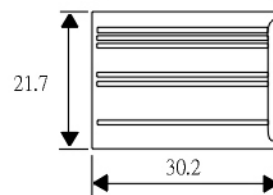

(6683)

# H HOUSING 6682-04

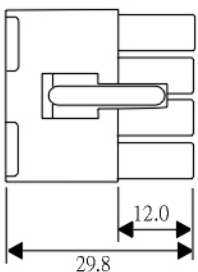
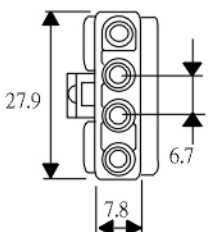

# H HOUSING 6683-04 6683E-04

Pcs/bag  
個數/袋  
500

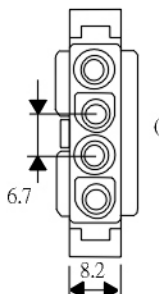
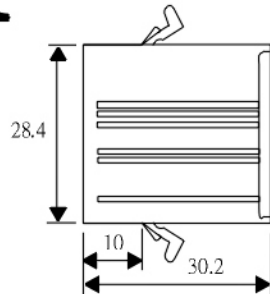

(6683E)

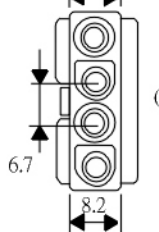
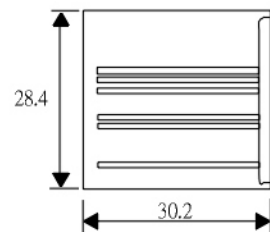

(6683)

# H OUSING 6682-06

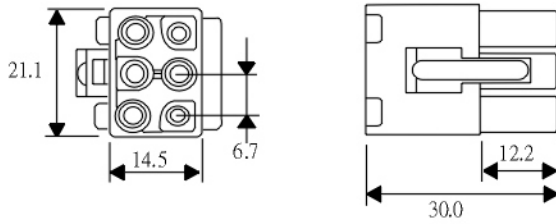

# H OUSING 6683-06 6683E-06

Pcs/bag  
個數/袋  
500

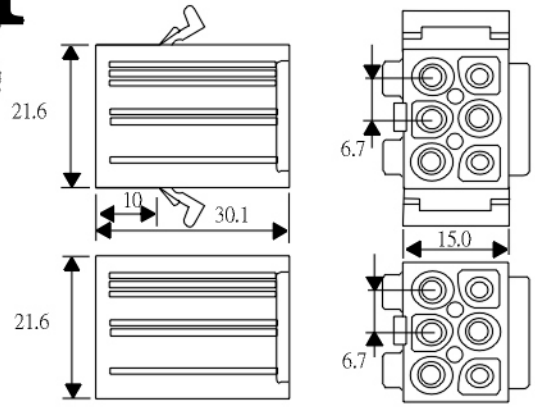

# H OUSING 6682-09

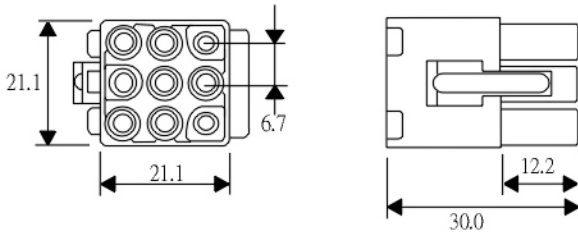

# H OUSING 6683-09 6683E-09

Pcs/bag  
個數/袋  
500

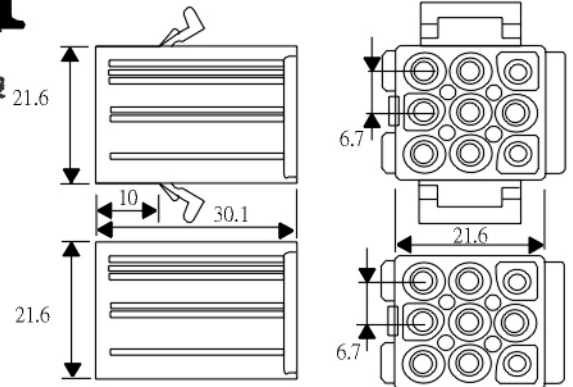

# H OUSING 6682-12

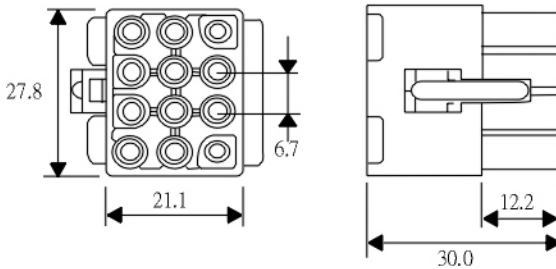

# H OUSING 6683-12 6683E-12

Pcs/bag  
個數/袋  
250

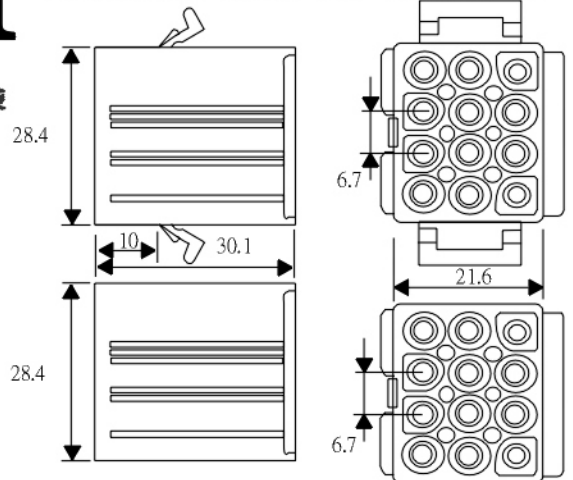

# H OUSING 6682-15

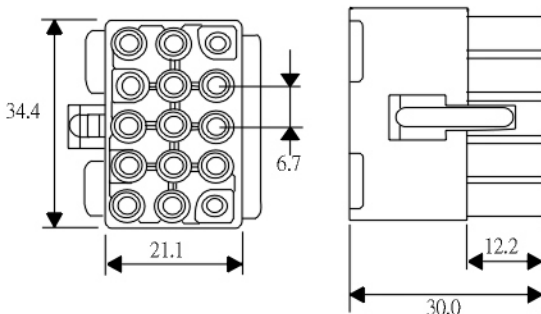

# H OUSING 6683-15 6683E-15

Pcs/bag  
個數/袋  
250

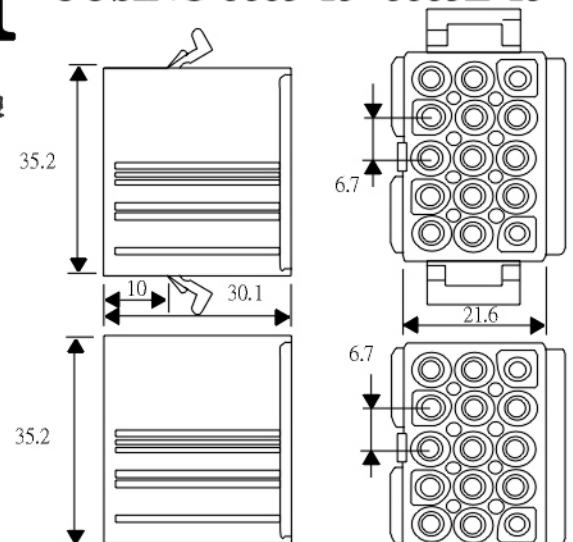



# 豪訊-承認書

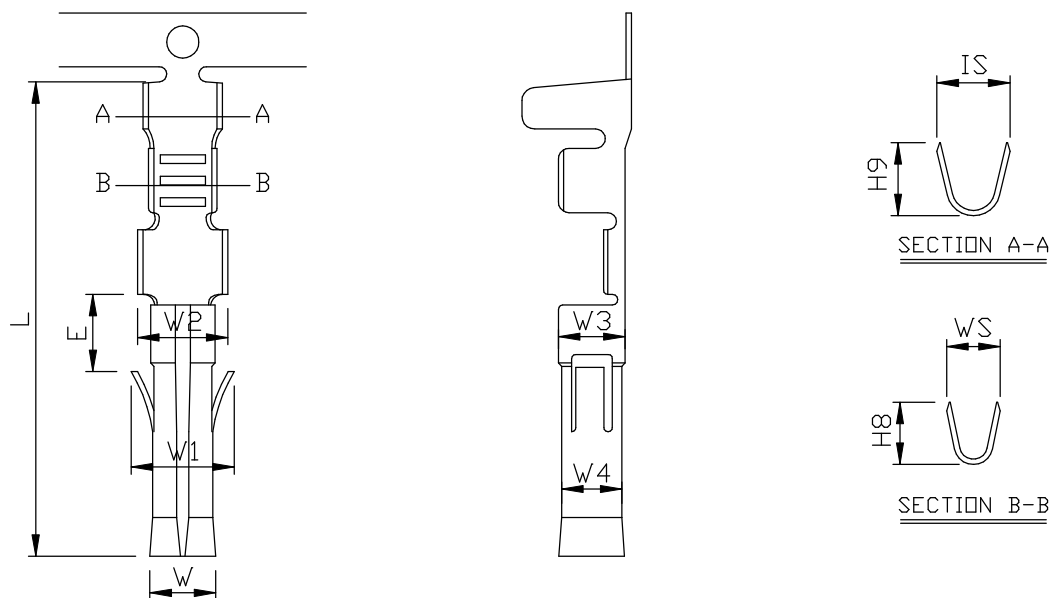

|       |            |           |        |          |        |      |                |
|-------|------------|-----------|--------|----------|--------|------|----------------|
| 適用電線  | 線皮外徑       | 端子材質      | 塑膠材質   | 包裝數量     | 重量     | 表面處理 | 連續, 單粒         |
| 20-24 |            | BRASS. SH |        | 5000 PCS |        | -2   | BS             |
| 尺寸標準  |            |           |        | 外觀標準     |        | 功能標準 |                |
| 項目    | 規格         | 重要度       | 備註     | 項目       | 規格     | 配合塑膠 | 塑膠編號           |
| T     | 0.25± 0.03 |           |        | M1       | JH     | 膠    | 插入力            |
| L     | 22.1± 0.3  |           |        | M2       | 三紋     |      | 脫拔力            |
| W     | 3.07± 0.1  |           |        | M3       | 倒角     | 公母對插 | 端子編號           |
| E     | 3.50± 0.2  |           |        | M4       | 無毛邊    |      | 插入力            |
| IS    | 3.60± 0.4  |           |        | M5       | 龜裂, 變形 | 其    | 脫拔力            |
| WS    | 2.60± 0.4  |           |        | 料規       |        |      | 材重             |
| H8    | 2.60± 0.25 |           |        | PITCH    |        | 他    | 配合 PIN         |
| H9    | 3.30± 0.25 |           |        | 沖壓距      |        |      |                |
| W1    | 4.40± 0.2  |           |        | 一沖數量     |        |      |                |
| W2    | 3.75± 0.2  |           |        | 備註:      |        |      |                |
| W3    | 3.2 ± 0.1  |           |        |          |        |      |                |
| W4    | (2.8)      |           | 配合 PIN |          |        |      |                |
| 修改紀錄  |            |           |        |          |        |      |                |
| 版次    | 年月日        | 修改內容      | 修改者    | 核對       | 製表     | 校對   | 日期             |
|       |            |           |        |          |        |      |                |
|       |            |           |        |          |        |      | 品名: JH-T6680-B |



# 豪訊-承認書

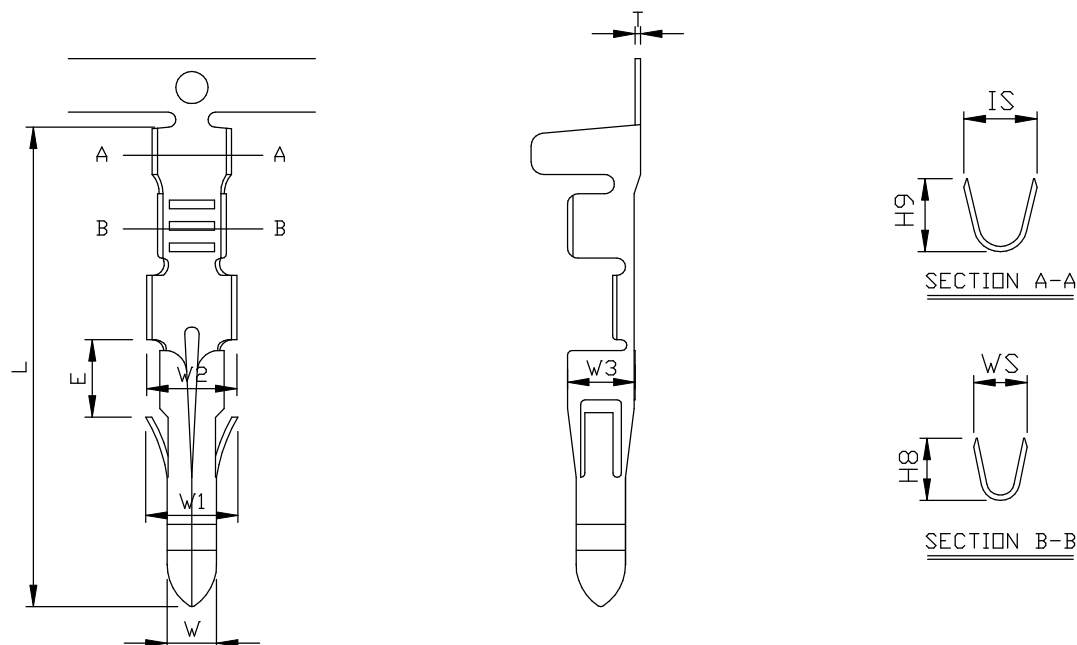

|       |            |           |      |          |        |                  |                |
|-------|------------|-----------|------|----------|--------|------------------|----------------|
| 適用電線  | 線皮外徑       | 端子材質      | 塑膠材質 | 包裝數量     | 重量     | 表面處理             | 連續, 單粒         |
| 20-24 |            | BRASS. SH |      | 5000 PCS |        | -2               | BS             |
| 尺寸標準  |            |           |      | 外觀標準     |        | 功能標準             |                |
| 項目    | 規格         | 重要度       | 備註   | 項目       | 規格     | 配合塑膠             | 塑膠編號           |
| T     | 0.25± 0.03 |           |      | M1       | JH     | 膠                | 插入力            |
| L     | 22.1± 0.3  |           |      | M2       | 三紋     |                  | 脫拔力            |
| W     | 2.30± 0.1  |           |      | M3       | 倒角     | 公<br>母<br>對<br>插 | 端子編號           |
| E     | 3.50± 0.2  |           |      | M4       | 無毛邊    |                  | 插入力            |
| IS    | 3.60± 0.4  |           |      | M5       | 龜裂, 變形 |                  | 脫拔力            |
| WS    | 2.60± 0.4  |           |      | 料規       |        | 其<br>他           | 材重             |
| H8    | 2.60± 0.25 |           |      | PITCH    |        |                  | 配合 PIN         |
| H9    | 3.30± 0.25 |           |      | 沖壓距      |        |                  |                |
| W1    | 4.40± 0.2  |           |      | 一沖數量     |        |                  |                |
| W2    | 3.75± 0.2  |           |      | 備註:      |        |                  |                |
| W3    | 3.2 ± 0.1  |           |      |          |        |                  |                |
|       |            |           |      |          |        |                  |                |
|       |            |           |      |          |        |                  |                |
| 修改紀錄  |            |           |      |          |        |                  |                |
| 版次    | 年月日        | 修改內容      | 修改者  | 核對       | 製表     | 校對               | 日期             |
|       |            |           |      |          |        |                  |                |
|       |            |           |      |          |        |                  | 品名: JH-T6681-B |